



Owner's Manual

Minimum Circuit Ampacity (MCA): 15A
Max Overcurrent Protective Device: 15A
Volts: 120 Amps: 15 Frequency: 60 HZ Phase: 1

Boiler Model GX10
Tested to UL 2523-2009 Rev. 04.
For wood fuel only



CONGRATULATIONS

You now own a Hawken. A boiler designed with your needs in mind. Use this manual for safety, installation and maintenance of your new Hawken. Please read the entire manual before installing or operating your boiler. **SAVE THESE INSTRUCTIONS.**

Locate your Serial number and Model Number inside the control box on the front of your Hawken.

Record your serial number and model number here:

Serial _____

Model _____

Please have this information available when contacting your local dealer or Hawken Energy for warranty, service, etc.
Hawken Energy Inc.
PO BOX 351
Shelby, MI 49455
231-861-8200
www.HawkenEnergy.com
custserv@hawkenenergy.com

SAFETY

DANGER

Risk of Fire or Explosion - Do not burn garbage, gasoline, drain oil or other flammable liquids.

WARNING

Risk of Fire:

Do not use chemicals to start unit firing.

Do not burn garbage, gasoline, fuel oils, or other flammable liquids or materials.

Do not operate with fuel-loading or ash-Removal doors open.

Do not store fuel or other combustible materials within marked installation clearances.

Inspect and clean flues and chimney regularly.

Do not pressurize this boiler.

Never operate boiler when water level is not completely full. This boiler has a safety feature installed to prevent overheating. If water temp reaches 190 degrees, this safety feature will disable blower fan and light. If no power to fan and light, press red reset button in rear of boiler near junction box.

Never operate boiler without a grounding rod properly installed at boiler.

In the event of a runaway fire turn off power to the unit.

CAUTION

Hot surfaces. Do not touch during operation. Keep face away from door area.

Keep children away.

Load fuel carefully or damage to boiler may result. Always take care to not allow hot coals or sparks from spilling out. Always remove ashes into a covered, non-combustible container. Do not allow ash level to build up above bottom door frame. Do not allow ashes to build up on steel surfaces.

Always comply with all applicable codes and regulations. For safety keep firing and ash pit doors tightly closed.

Keep fire and coals at least six inches back from door chute. Keep ashes from piling against firebox rear plate. Do not allow burning wood or coals to touch door, door frame or door chute. Do not use inner door shield to push wood into firebox. Place wood into firebox carefully to avoid damage to the firebrick. Stack all wood in the same orientation, front to back, to prevent bridging over the firebrick vents. Use a variety of log sizes to maximize wood volume in firebox. Always use dry, seasoned hardwood. Green wood will create excessive creosote and hamper the full function of your Hawken GX series boiler.

Disposal of Ashes: Ashes should be placed in a steel



SHELBY, MI



487-O-01-2
Solid Fuel Fired Boiler Assembly

Model: GX10 No. _____
Tested to UL 2523-2009

VOLTS: 120	MINIMUM CIRCUIT AMPACITY (MCA): 15A
AMPS: 15	
FREQUENCY: 60 HZ	MAX OVERCURRENT PROTECTIVE DEVICE: 15 A
PHASE: 1	

REFER TO OWNERS MANUAL

- FOR BASIC OPERATING INSTRUCTIONS AND MAINTENANCE INSTRUCTIONS
- SWITCH IN UP POSITION FOR BOILER ON, SWITCH IN DOWN POSITION FOR BOILER OFF
- FOR WOOD BURNING ONLY

USE A CHIMNEY CAP SUITABLE FOR WOOD COMBUSTION. CLEARANCE TO COMBUSTIBLES: 16" SIDES AND REAR. 96" TOP. FOR INSTALLATION ON NONCOMBUSTIBLE FLOORING ONLY. LOAD FUEL CAREFULLY OR DAMAGE MAY RESULT. NOT TO BE CONNECTED TO AN EXISTING BOILER SYSTEM. CONNECTION TO PLATE EXCHANGERS IS ACCEPTABLE.

DANGER - RISK OF FIRE OR EXPLOSION
DO NOT CONNECT THIS UNIT TO A CHIMNEY FLUE SERVING ANOTHER APPLIANCE.
DO NOT USE CHEMICALS OR FLUIDS TO START THE FIRE.
DO NOT BURN GARBAGE, GASOLINE, NAPHTHA, ENGINE OIL, OR OTHER INAPPROPRIATE MATERIALS

WARNING - RISK OF FIRE
THE HEAT EXCHANGERS, FLUE PIPE, AND CHIMNEY MUST BE CLEANED REGULARLY TO REMOVE ACCUMULATED CREOSOTE AND ASH. ENSURE THAT THE HEAT EXCHANGER, FLUE PIPE, AND CHIMNEY ARE CLEANED AT THE END OF THE HEATING SEASON TO MINIMIZE CORROSION DURING THE SUMMER MONTHS. THE APPLIANCE, FLUE PIPE, AND CHIMNEY MUST BE IN GOOD CONDITION. THESE INSTRUCTIONS ALSO APPLY TO A DRAFT INDUCER.
UNIT WILL NOT OPERATE WITHOUT ELECTRICAL POWER.
DO NOT STORE SOLID FUELS WITHIN THE COMBUSTION CLEARANCES. DO NOT OPERATE BOILER WITH DOOR OPEN. DO NOT LEAVE BOILER UNATTENDED WITH DOOR OPEN.

Nameplate Illustration

Component Locations and Sticker Placement Guide

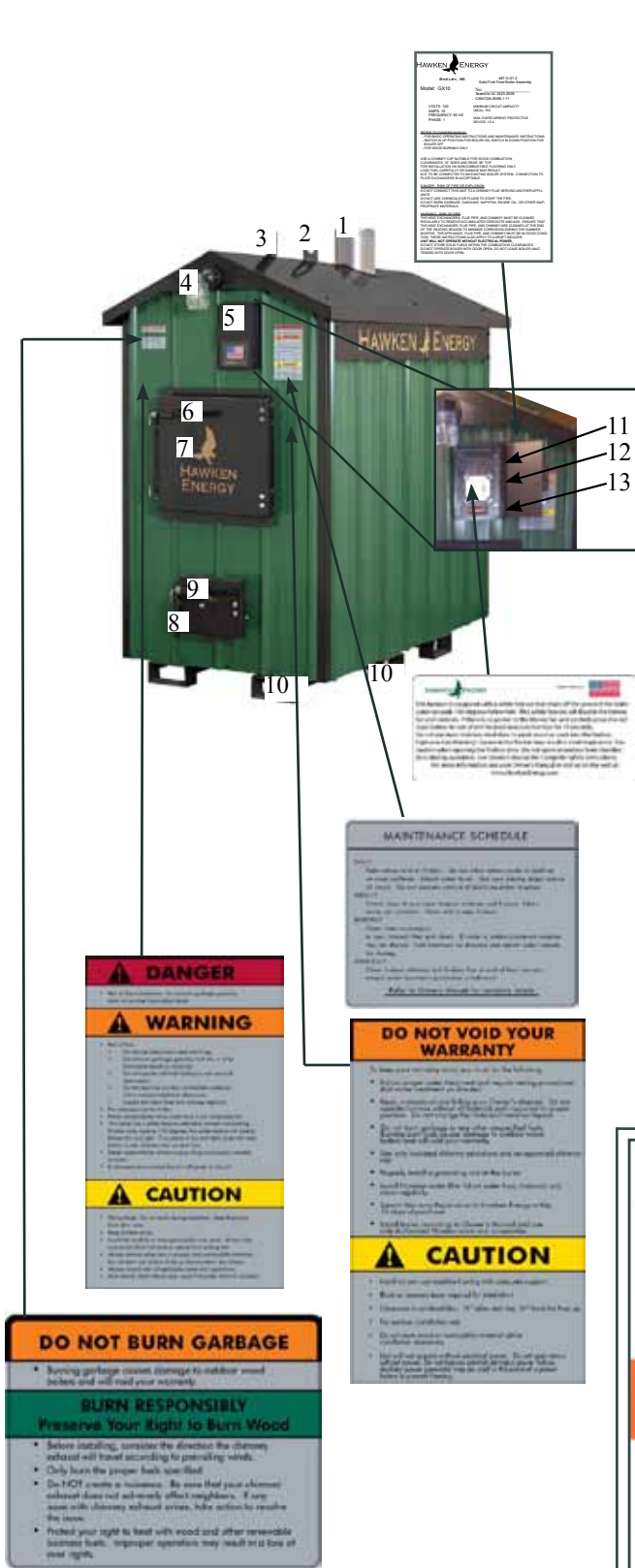

1	Insulated Chimney	12	Light & Blower Switches
2	Lift Hook	13	Temperature Controller
3	Vent/Water Level Indicator	14	Flue Area
4	Light	15	Feed Lines
5	Control Box Door	16	Return Lines
6	Firebox Door Handle	17	Electrical Junction - Receptacle
7	Firebox Door	18	Blower/Solenoid Assembly
8	Secondary Burn Chamber	19	Flue Access Door
9	Secondary Burn Chamber Handle	20	Drains
10	Forklift Guides	21	Temperature Probe
11	Access Panel		

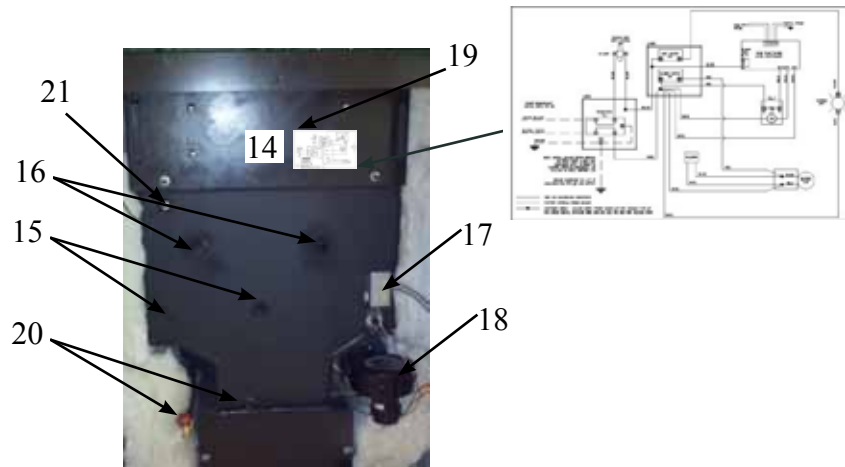

PHASE 2 QUALIFIED
U.S. Environmental Protection Agency
Hydronic Heater Program

This model is qualified by EPA to meet Phase 2 smoke emission levels. Models with lower smoke emissions may reduce your risk of respiratory illness.

SMOKE EMISSIONS

EPA Phase 2
Emission Level
0.12 lbs/1000 BTU
This Model
0.14 lbs/1000 BTU

MANUFACTURER:	Hawken Energy
MODEL NUMBER:	GX-10
MAXIMUM OUTPUT RATING:	144,870 BTU/HR
8-HOUR OUTPUT RATING:	76,887 BTU/HR
8-HOUR AVERAGE EFFICIENCY*:	69% (high heating value) 73% (low heating value)
ANNUAL EFFICIENCY*:	64% (high heating value) 69% (low heating value)
PARTICLE POLLUTION:	2.2 GRAMS/HR (average) 0.14 LBS/MILLION BTU OUTPUT

*Performance may vary due to heating requirements, proper sizing of boiler to home, and owner operation. Follow the operator's manual and burn only dry seasoned wood. Tested with EPA's method 6E (see section 6.0 of 610710).

Burn Wise

For more information go to www.epa.gov/burnwise

The U.S. Environmental Protection Agency has determined, based on test results from Omni, an independent accredited laboratory, that this model line meets the U.S. EPA Hydronic Heater Voluntary Program Phase 2 emission level. To minimize smoke, always operate your hydronic heater in accordance with the manufacturer's instructions found in the owner's manual. Additional information about EPA's Program is available at www.epa.gov/woodheaters.

container with a tight-fitting lid. The container of ashes should be moved outdoors immediately and placed on a noncombustible floor or on the ground, well away from combustible materials, pending final disposal. If the ashes are disposed of by burial in soil or otherwise locally dispersed, they should be retained in the closed container until all cinders have thoroughly cooled. Other waste shall not be placed in this container.

Do not allow ash level to build up above bottom door frame. Take care to pull ashes away from rear steel of firebox. Always comply with all applicable codes and regulations. Do not store wood or combustible material within installation clearances. All cover plates, enclosures, and guards must be maintained in place at all times, except during maintenance and servicing.

In case of a power outage: Auxiliary power generator may be used in the event of a power failure to prevent freezing by unplugging the pump from the receptacle in the rear of the unit and plugging it into the generator. To operate the furnace for heating purposes if there is a prolonged power failure it will be necessary to connect a generator to the main power connection in the rear of the unit. It is acceptable to wire the unit with a standard electrical plug to make a generator connection easier.

Do not overfill firebox. A small intense fire is preferable to a large smoldering one to reduce the amount of creosote deposition. A Hawken GX series system requires circulation of water to dissipate heat. Too much stored heat may cause damage to your Hawken. For outdoor installation.

This boiler has a safety feature installed to prevent overheating. If water temp reaches 190-199 degrees Fahrenheit, this safety feature will disable blower fan and aquastat. If no power to fan, press red reset button in rear of boiler near the junction/receptacle box.

Never operate boiler without a grounding rod properly installed at boiler. Do not store fuel or other combustible material within a minimum installation clearance of 16" from the sides and rear, and 96" from the floor above top of boiler. DO NOT install or operate, nor allow others to install or operate boiler without first reading, understanding and following the Owner's Manual.

COMPONENTS		
COMPONENT	IDENTITY	MODEL
Blower Motor	Fasco	B24220
Blower Control	Love/Dwyer	TSWB-101
Snap Disk	Thermo-Disk	60t11-610015
Burner ON/OFF Switch	Leviton	145-2is

Firebrick	Standard Firebrick	Contact Hawken
Relay	White Rodgers	90-341
Light	Hampton Bay	WB0317 (252-550)
Insulated Chimney	Selkirk	SPR6L24

DO NOT VOID YOUR WARRANTY

To keep your warranty valid, you must do the following: Read, understand and follow your Owner's Manual. Do not burn garbage or any other unspecified fuels. Burning such fuels causes damage to outdoor wood boilers and will void your warranty. Properly install a grounding rod at the boiler. Follow proper water treatment and testing procedures. Only operate boiler when water level is completely full. Pump must run continuously whenever boiler is being used.

Always install boiler with a Hawken authorized 6" chimney cap (sold separately). Never operate or store boiler without an approved chimney cap. Chimney extensions and chimney caps should be locked to mating pieces. Support chimneys higher than 8' with wires or bracing. The Hawken GX series utilize 6" stainless steel insulated chimney pieces. Any extensions, accessories or cap must be of the same make and material and should meet ULC-S610 and ULC-S604. For best fit, contact your Hawken rep or Hawken Energy for authorized Hawken parts. Install Hawken water filter kit on water loop (indoors) and clean regularly. Submit Warranty Registration to Hawken Energy within 15 days of purchase.

Do not operate your furnace at temperatures below 140°F except at startup and shutdown. If your heating load pulls more heat than the rated output your operating temperatures will drop below the recommended temperature range of 172 to 182°F. Your furnace is equipped with an LED indicator that alerts the operator if the temperatures drops below 140°F. Do not alter the operating parameters of your controller. Doing so may void your warranty.

Installation to be performed by a qualified installer and will comply with all the requirements of the authority having jurisdiction over the installation. Install boiler according to Hawken Installation Guide and use only Authorized Hawken parts and accessories.

Note: Check the Hawken web site for periodic product updates and service bulletins. Visit www.HawkenEnergy.com/servicebulletins/ at least semiannually and follow any and all instructions listed.

Store firewood fuel in a dry location. Stack fuel carefully, not higher than 5'. Do not store fuel within the installation clearances of the unit. Do not store fuel in a way that it will interfere with loading or maintenance operations of the unit.

Creosote - Formation and Need for Removal - When wood is burned slowly, it produces tar and other organic vapors, which combine with expelled moisture to form creosote. The creosote vapors condense in the relatively cool chimney flue of a slow burning fire. As a result, creosote residue accumulates on the flue lining. When ignited this creosote makes an extremely hot fire. The chimney connector and chimney should be inspected at least twice monthly during the heating season to determine if a creosote buildup has occurred. If creosote has accumulated it should be removed to reduce the risk of a chimney fire. Establish a routine of checking for creosote regularly. Check for creosote in the firebox, and the blower chamber in the rear of the unit. Check daily for creosote buildup until experience shows how often cleaning is necessary. The hotter the fire the less creosote is deposited. Cleaning may be required more often when the weather is milder and less often when the weather is colder. Have a clearly understood plan to handle a chimney fire.

Use a chimney cap suitable for wood combustion.

Clearance to combustibles: 16" sides and rear. 96" top.

For installation on noncombustible flooring only.

Installation clearances must be adhered to. Not doing so may result in a fire hazard.

Load fuel carefully or damage may result.

Not to be connected to an existing boiler system.

Connection to plate exchangers is acceptable.

Do not connect this unit to a chimney flue serving another appliance.

Do not use chemicals or fluids to start the fire.

Do not burn garbage, gasoline, naphtha, engine oil, or other inappropriate materials

The heat exchangers, flue pipe, and chimney must be cleaned regularly to remove accumulated creosote and ash. Ensure that the heat exchanger, flue pipe, and chimney are cleaned at the end of the heating season to minimize corrosion during the summer months. The appliance, flue pipe, and chimney must be in good condition. Ensure that the blower/solenoid assembly and the air induction area are cleaned thoroughly at least twice per burning season, more as needed.

Unit will not operate without electrical power. Do not open doors without power. Do not bypass controls during a power failure.

Do not store solid fuels within the combustion clearances.

Do not operate boiler with door open. Do not leave boiler unattended with door open.

The Hawken Energy GX series furnaces utilize firebrick refractory to contain the high temperature burn of the gasification process. Protect your firebrick by taking the following precautions. Before start up check brick to make sure there are no cracks or chips. Visually inspect the lower burn chamber to make sure all the brick are standing vertically, not tilted or out of place. Use caution when loading wood into the firebox. Do not drop heavy pieces of

wood onto the brick. Use caution when raking or shoveling ashes and coals. Do not operate furnace if pieces of brick are missing. Wear and signs of stress are normal. Do not alter or change your unit, including firebrick and insulation. Insulation and firebrick are not covered by the warranty. New brick may be obtained by contacting Hawken Energy. Keep all doors closed when operating unit and maintain all seals in good condition.

Do not block blower inlet fan area. Allow proper airflow around boiler. Keep insulation away from fan inlet.

Finding the Best Location for Your Hawken

When identifying the ideal location for your Hawken, please consider the following:

Review the HPBA Best Burn Practices: http://static.hpba.org/fileadmin/PDFs/Tier_IV_Outdoor_Wood_Boiler_Best_Burn_Practices_-_MH1.pdf.

When possible, have the boiler door open towards prevailing winds. This helps disperse the smoke while loading the boiler. When possible locate boiler 30 to 50 feet from any structure. Consult with your insurance company for minimum distances. Always install boiler with a Hawken authorized chimney cap to reduce heat loss, keep rain out, to serve as a spark arrestor, and to disperse smoke. Locate boiler so that prevailing winds will not cause a nuisance for neighbors. Protect your right to burn wood! When possible, locate boiler downwind from nearby buildings. Hawken GX series units are designed for low emissions. Some smoke may be present, especially at startup and filling. Install on non-combustible flooring with adequate support. Hawken boilers do not require a cement slab. Boiler feet may be set on 4-inch thick header blocks that are level, centered, and properly supported. Hawken GX series boilers utilize a unique frame design to allow forked lifting from three sides. The unit is very heavy; please use caution. A lift loop is also mounted to the top of the boiler for crane type lifting. A concrete pad is not required for placement. 4 to 8 concrete blocks may be used instead. Boiler base/feet may be set on 4-inch thick header blocks that are level, centered, and

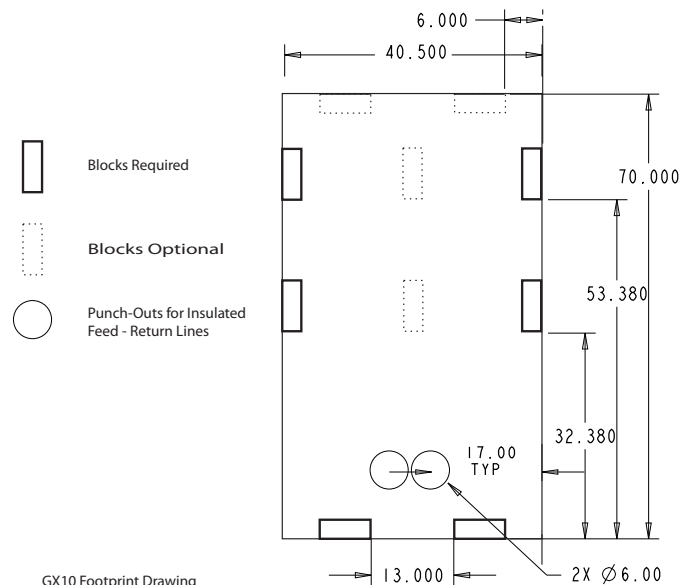

properly supported. If pouring concrete, don't forget to leave a space for the underground feed and return pipe.

Although outdoor prevailing wind and smoke considerations should be given first priority, your outdoor boiler location selection may also minimize the amount of purchased pipe required. Authorized Hawken underground pipe loses very little heat, so longer distances will not cause significant heat loss, but reducing distance will reduce cost of purchased pipe. Finally, keep in mind that the underground pipe must enter the home or building to be heated, and plan for this accordingly.

Preparing the Location for Your Hawken

When preparing the location for your boiler, please consider the following:

When possible, install underground pipe before delivery and placement of boiler. This simplifies the placement process. If installing boiler on a cement pad, it is recommended to install underground pipe before pouring cement pad. Make sure to leave a hole in cement pad (minimum 12" square) between rear legs for underground pipe to connect to rear of boiler. Installation should be performed by a qualified installer. For customers who require chimney extensions, insulated pipe is required. Contact Hawken to ensure that the insulated chimney extensions you purchase mate with the factory installed chimney on your unit.

Your warranty requires the use of Hawken authorized water treatment. You **MUST** take the steps listed below to ensure the proper operation of your Hawken. Further, your Hawken and its components will receive better protection against corrosion, your filter will require cleaning less frequently and your system will last longer.

First Time Fill - Water Testing

1. Before you fill your boiler the first time, purchase from your Hawken Rep the appropriate amount of Hawken authorized water treatment. Follow the directions on the bottle for how much to add to your system. Your dealer will also provide you with sample test bottles and labels so that you can submit a water sample annually for laboratory testing (follow instructions included with test bottles.)
2. Once your installation is complete, fill your new boiler so that it is approximately half full of water. Make sure all valves are closed. Do not fill boiler with water until your installation is complete, and the drain valve is properly installed.
3. Add the appropriate amount of Hawken authorized water treatment.
4. Fill your boiler until it is completely full of water. You will know it is full when water spills out of the vent tube onto the roof of the boiler.
5. Once full of water, do not start a fire in your boiler yet.
6. Open all necessary valves, wait 5 minutes, then turn on your pump. Allow the pump to circulate the water for at least 2 to 4 hours.
7. After the pump circulates the water for at least 2 to 4

hours drain a small sample of water FROM THE DRAIN VALVE LOCATED AT THE BOTTOM OF THE BOILER. Follow the enclosed directions to send this water sample for testing. You may now startup your boiler.

8. Once your water sample is received by the laboratory and tested, you will receive a lab report containing the results from your water sample test. Please be sure to legibly print your information on the label provided. Please provide an E-mail address where you would like your report to be sent. If your water is found to contain anything harmful to your Hawken, further action on your part will be specified in this lab report. If any further action is required on your part, you must comply with the instructions provided in the lab report. Once you do so, you will then be required to submit another water sample to the lab for testing. Please take this sample according to instructions below under "Periodic Testing". A "satisfactory" water sample report must be on file at Hawken to maintain your warranty and this must be renewed annually. Please save reports for your own records.

9. Follow instructions below for Periodic Testing. Your Hawken authorized water treatment will indicate how often such testing is necessary (currently once per year). Any changes to this testing procedure will also be specified in service bulletins posted at www.HawkenEnergy.com/servicebulletins/ which you should check semiannually.

Periodic Water Testing

Periodic water testing must be completed at least once per year. This is a free test, but in order to maintain your warranty you must comply with the following instructions.

1. First, a sample of water must be taken from the boiler. To do so, please observe the following steps:
 - a. The boiler must be turned off and cooled in order to take the water sample. If the boiler is going to sit idle during the summer months, it is best that testing and proper amounts of water treatment chemical are added to the boiler prior to the idle summer months.
 - b. NEVER DRAIN YOUR BOILER AND LEAVE IT EMPTY OF PROPERLY TREATED WATER. Always have your boiler full of properly treated water.
 - c. Let the fire burn out. Allow the boiler to cool until the water temperature is below 80 degrees F.
 - d. Remove the ash. Lightly scrape the inside of the firebox to remove the ash.
 - e. Shut off the power to the boiler to stop the pump(s).
 - f. Make sure the ball valves to the pumps are in the open position to avoid any air lock upon restart. Never attempt to operate the pump(s) with the ball valves (to pumps) in the closed position.
 - g. If you have a forced air furnace with a second Hawken thermostat, turn the thermostat off.
 - h. Attach a hose to the water jacket drain at the bottom of the boiler.
 - i. Open the water jacket drain until the water runs clear. Close the drain. This is an important annual maintenance item that flushes any sediment buildup from the boiler.

- i-1. Repeat steps h and i from second drain.
 - j. Add chemical as needed. If a significant volume of water was required to be drained from the boiler to get the water to run clear, refill the boiler using your in-house fill valve.
 - k. Turn on the power to the pump and circulate the boiler water for 2 to 4 hours. Turn pump and power off again.
 - l. With a water sample bottle ready to fill, open the water jacket drain again and fill the water sample bottle.
 - m. Turn power and pump back on, and return boiler to service when ready.
2. Send water sample to laboratory for lab testing. Please be sure to legibly print your information on the label provided. Please provide an e-mail address where you would like your report to be sent. Follow mailing instructions included with the water sample test bottles.
 3. A water sample report will be returned to you via e-mail (be sure to include your e-mail on the label).
 4. If the water sample lab report indicates that the "Treatment level is satisfactory", then no further action is required. If the report indicates that the "Treatment level is low", then the lab report will specify what you need to do.
 5. Carefully follow the instructions specified in the water sample lab report (if any), and then send another water sample to the lab for another test (see Step 1 above). A "satisfactory" water sample report must be on file at Hawken to maintain your warranty, and this must be renewed annually. Please save reports for your own records.

Hawken Startup/Shut Down

Hawken Startup Procedures

Please observe the following steps when starting the boiler:

1. Observe all safety precautions.
2. Ensure that the installation has been completed properly.
3. Make sure the boiler is full of water. Verify this with the water level indicator AND by filling the boiler until water flows out of the vent tube on the roof peak.
4. Make sure the boiler water has been properly treated with authorized water treatment.
5. Open all valves. Allow 5 minutes for water to fill pump and system.
6. Turn on power and make sure pump is running. Never operate boiler without the pump fully circulating water.
7. Make sure fan switch is operational. Fan switch is located on the front of the boiler inside the control box. Turning the fan switch to the ON position (up).
8. The boiler water temperature is controlled by an electronic temperature controller. The temperature controller comes set from the factory to 182°F high and 172°F low. The temperature controller will automatically control the blower to maintain the water temperature between this range.
9. Build a small fire in the firebox, and allow boiler temperature to rise SLOWLY.
10. When the temperature reaches 170°F, the boiler is ready to be filled to capacity for full operation. Note: Gasification furnaces rely on multiple factors. Full combustion efficiency

may take 4 to 6 hours to be achieved. Smoke may be visible during this time.

Hawken Shut Down Procedures

Please observe the following steps when shutting down the boiler:

1. Observe all safety precautions.
2. Allow time for the fire and coals to completely burn out.
3. Empty all the ashes and lightly scrape out the firebox and secondary burn chamber to remove all ashes. Also clean the heat exchangers in the rear of unit. See Hawken Maintenance for more details.
4. Fill the system with water until it is completely full.
5. Flush and clean the in-line water filter.
6. Make sure the proper water treatment procedure is followed (see "Periodic Water Testing").
7. Make sure the chimney cap is in place to prevent rainwater from entering firebox.
8. If you have a forced air furnace with a second thermostat controlling your indoor furnace blower fan, be sure to turn off the power to this thermostat.

Operation

The Hawken GX series furnaces use a digital temperature switch to regulate the unit's temperatures. The 3 digit display indicates the unit's water temperature from a probe at the rear of the furnace. The Digital Temperature Switch has a high and a low set point for controlling the water temperature. This control also has a conductivity probe input. This input supplies 12 VAC to the probe to check for low water condition. A water level sensor is connected to the digital input. When the control detects an open signal, the unit is low on water. In this case the water LED on the face of the control lights and power to the air input for the unit is shut off. When this happens it will be necessary to refill the unit with water.

Fuel LED indicates the stove is out of wood or operating at a temperature below 140°F.

Water LED indicates the unit is low on water.

In normal operation, the probe temperature will be shown on the display.

In case of alarm or error, the following messages can be shown:

- Erl = Memory Error
- ooo = Open Probe Error
- --- = Short Circuit Probe Error

There is no routine maintenance required for the temperature switch. Do not alter the settings on your Digital Temperature Controller.

Hawken Maintenance

The following maintenance items must be followed.

Remember to observe all safety precautions.

1. Check Water Level/Fill – Always keep the boiler full of water. On a daily basis, check the water level indicator

located in the vent tube at the peak of the roof towards the front of the boiler. If not full, open in-house fill valve until full. Normally, this step should be taken once a month by opening the in-house fill valve for a few seconds until water spills out on the roof of the boiler. Add water to boiler slowly.

2. Rake Ash Level/Remove As Needed – Before each loading of the boiler with wood, rake coals level in the firebox. Do not allow level of coals to rise above the bottom level of the door frame. Remove ash/coals with a shovel as needed to keep below this level.

3. Remove ash and coals every week and scrape firebox clean. Never operate the boiler with a fire in it with the door open, except for brief periods while loading wood or removing ash. Always remove ash into a covered, non-combustible container. Clean ash from all firebox surfaces, especially the rear plate. **DO NOT ALLOW ASH TO BUILD UP ON THE STEEL SURFACES.**

4. Clean Lower Ash Chamber. Use caution. Only open the lower front door when furnace is switched to off position. Using the provided cleaning/scraping tool, remove ash from lower chamber as necessary, at least every week. Always remove ash into a covered, non-combustible container.

5. Heat Exchanger Cleaning. Observe all safety precautions. Wear gloves and eye protection. Turn off blower before performing maintenance. Every other week remove the rear top door from your furnace to clean the heat exchange tubes (It is recommended that you perform the first cleaning 6 to 7 days after the initial firing). Remove the rear top door by unscrewing the 4 wing nuts on the top rear bolts and pulling the ash door out. Remove the stainless steel deflector from the left chamber. Use the provided brush, to clean the heat exchange tubes. Clip the brush to the extension wire. Feed the brush, handle (loop) first, into the tubes and pull brush through each tube to clean and remove ash build up. To clean the vertical tubes in the left-hand chamber feed the brush into the tubes, bristles first. Use a duster or vacuum to remove ash from exhaust areas and drip tray under rear door. Clean your furnace regularly to maintain the highest efficiency. Replace door after cleaning. See the video explaining these step further at www.HawkenEnergy.com.

6. Inspect Catalyst. While cleaning the heat exchange area check the catalytic disk. Make sure the catalyst is well seated and clean. If deeper cleaning of the catalyst is required visit www.HawkenEnergy.com for instructions.

7. Clean Air Feed Chamber – Smoke and creosote can build up in the air feed chamber beyond the blower fan. Remove the blower by uncoupling the latch behind the blower on the outside of the air feed chamber. Tilt the fan out and carefully remove the fan/solenoid assembly. Pull the solenoid plate out of the box and remove creosote from inside the box using a scraper tool. Carefully replace the fan/solenoid assembly.

From the firebox push the 1.5" wire brush down into the channel located in the rear left of the firebox. It may be necessary to remove some of the firebrick, starting from the

back, to fully clean this channel. See the video explaining these step further at www.HawkenEnergy.com. Clean the air feed chamber every six months of operation or more often as needed.

8. Inspect/Clean Filter (inside house/building) – Inspect filter for any sediment. When necessary, flush filter by opening the Filter By-Pass valve and close the valves on both sides of the visible flow filter. This allows the system to continue to circulate while you discharge the filter of all collected materials. Open the ball valve on the clean water side of the filter. Then, while holding a bucket under the filter, open the valve at the bottom of the filter to flush out the stainless steel filter, close that valve again once clear. This method generally cleans the filter without disassembly. Open both filter valves and close the by-pass valve. This should be done once a month. Occasionally, the stainless steel filter will appear dirty even after the above flush. In such cases, open the Filter By-Pass valve and close the valves on both sides of the visible flow filter. Filter and housing can be very hot. Allow to cool before handling. The filter can then be removed and cleaned by hand.

9. Door Rope/Seal – Inspect door seal fire rope monthly or as needed. Make sure door seals properly to prevent air from entering boiler; this will cause the boiler to overheat and can cause serious damage to the boiler. If necessary, replace fire rope. If necessary, adjust door for proper fit. Never operate the boiler with a fire in it with the door open, except for brief periods while loading wood or removing ash. When replacing fire rope or adjusting door for proper seal, be sure to remove any fuel from boiler to prevent overheating, since door may be open for more than a few minutes.

10. Chimney/Flue Inspection – Inspect chimney and flue monthly and clean as needed. Clean chimney and flue annually. Perform cleaning and maintenance only when no fire is present in the firebox and ashes are cooled completely.

11. Water Treatment – Ensure proper water treatment - see above.

Wiring Diagram

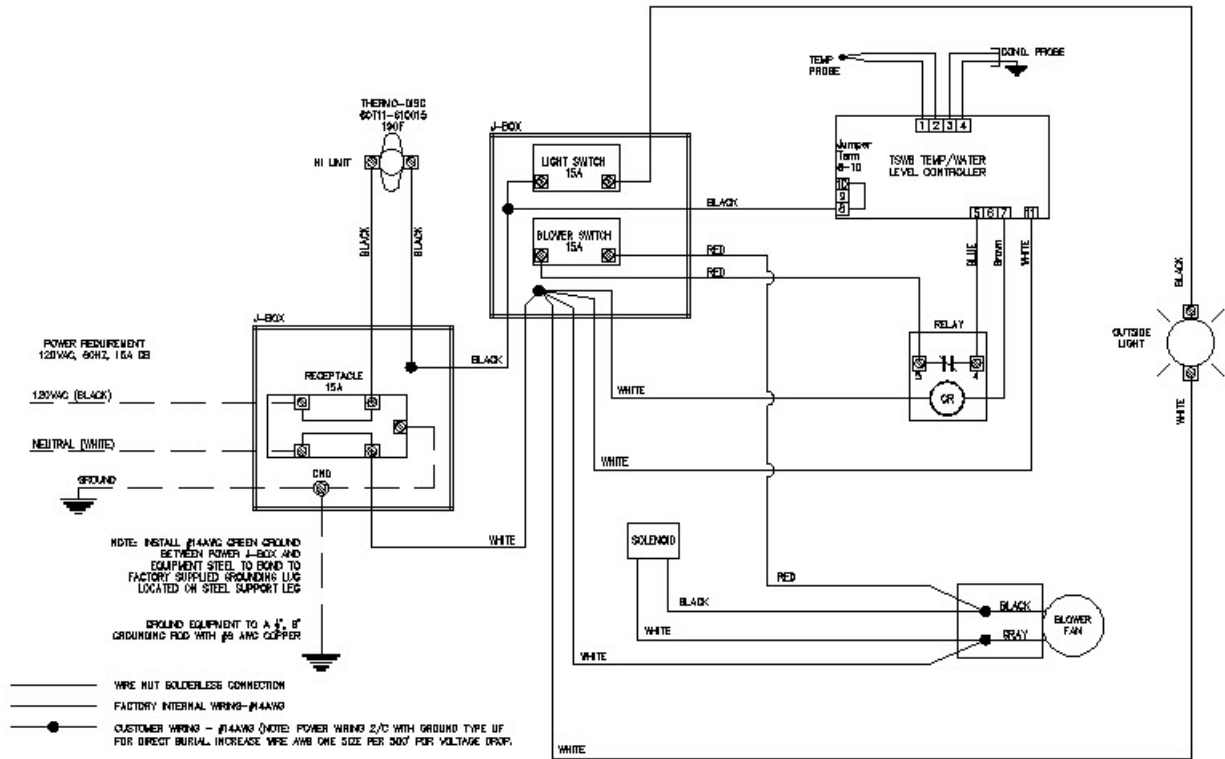

Wiring Schematic

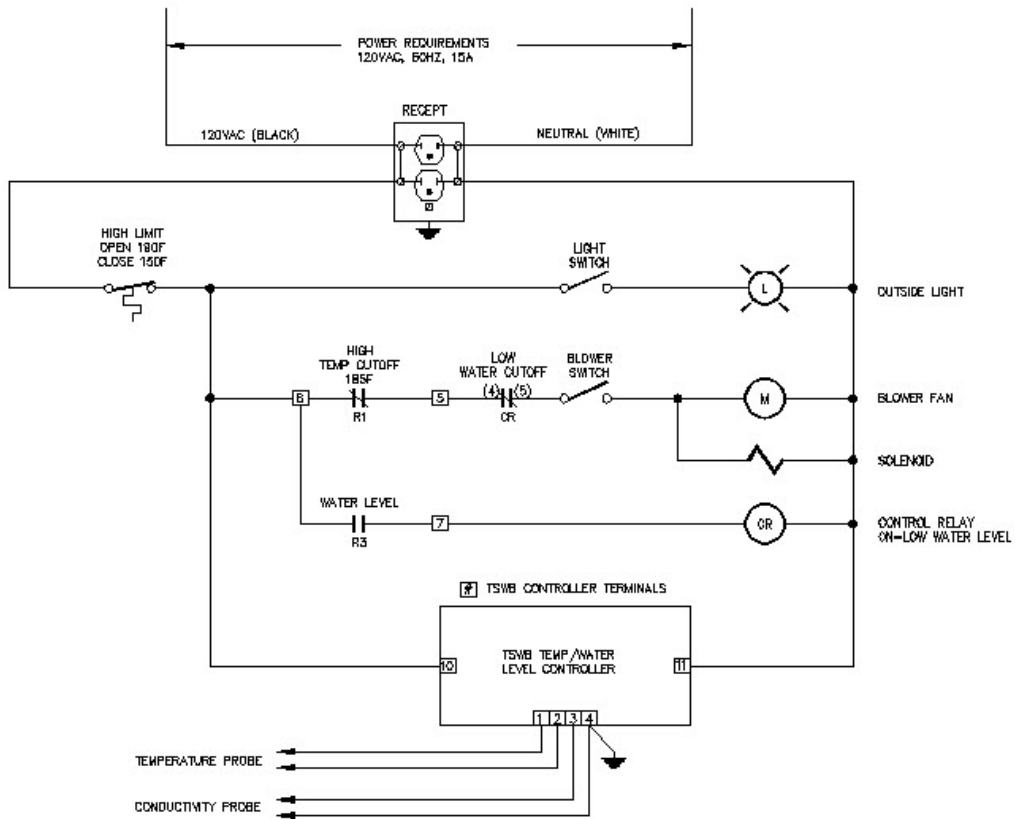

Return this page to Hawken Energy, Inc.

- I have received and read or will read the Owners Manual completely before I install and/or fire my Hawken Energy outdoor wood boiler.
- I agree to monitor and test the water in the system according to instructions in the Owners Manual.
- I agree to burn wood only.
- I agree to use properly installed grounding rod at the outdoor wood boiler, and to use only Hawken authorized parts in my outdoor boiler installation.
- I agree to follow all the operations and maintenance procedures listed in the Owners Manual.
- I acknowledge that my failure to abide by the above shall operate to void these warranties.

Warranty Registration

Serial No. _____ Model _____ Date of Purchase _____

Name _____
 Last First Middle Initial

Street _____

City _____ State/Prov. _____ Zip/Postal Code _____

E-mail _____

Phone _____

How did you first hear of Hawken Boilers? _____

Rep Name _____ City _____ State _____

Owners Signature _____
 (All information must be included)

I have read and understand the warranty. Acknowledgement of your warranty registration will be sent to you upon receipt by Hawken Energy Inc. If you do not receive such acknowledgment within two months, please contact your dealer/rep or Hawken Energy. Hawken Energy does not disclose this information to outside sources.
 Mail to Hawken Energy, P.O. Box 351, Shelby, MI 49455

Follow these important steps to keep your warranty valid:

- Rake ashes in primary fire box. Do not allow ashes to build up on steel surfaces in firebox.
- Remove ashes from secondary burn chamber every three days or as needed.
- Do not overfill your boiler. Do not use the inner door shield to force wood or ashes into the firebox.
- Clean the rear heat exchanger every 2 weeks or more often if needed to maintain efficiency.
- Submit a water sample to Hawken for testing at least once every 12 months. Add water treatment as needed according to the instructions in the Owner's Manual.
- Add water to the boiler as needed. Do not operate the boiler with low water levels.
- Inspect door rope seals and replace as needed
- Follow all maintenance and other instructions specified in the Owner's Manual.

Mail to:
 Hawken Energy
 P.O. Box 351
 Shelby, MI 49455

Dear New Hawken Owner,

Thank you for purchasing a Hawken Energy outdoor furnace and registering your furnace warranty. Below you will find a brief survey about your furnace purchasing experience. Please complete this with your warranty registration. Other Hawken customers have helped us in the same way and we always appreciate the opportunity to consider your input.

1. Did you get other estimates before deciding on Hawken Energy? Yes No
2. What other brands did you consider? _____
3. Why did you decide on a Hawken Energy outdoor furnace? (check all that apply)
 Reputation Warranty Product Features Factory Rep
 Recommendation Lowest Price Other _____
4. How did you hear about our company? (check all that apply)
 Word of mouth Internet Newspaper
 Magazine _____ Show _____
 Other _____ Highway Display Furnace
5. Was your installation done in a real and professional manner? Yes No Self Install
6. Please describe your overall satisfaction with the Hawken Furnace.
 Very Satisfied Somewhat Satisfied Somewhat Unsatisfied Very Unsatisfied
7. Please describe your overall satisfaction with the Hawken Factory Rep.
 Very Satisfied Somewhat Satisfied Somewhat Unsatisfied Very Unsatisfied
7. Would you recommend Hawken Energy to your friends and neighbors? Yes No

Comments: _____

Thank you for completing this survey. We would also appreciate photos of you and your Hawken Furnace to accompany this survey. Look us up on Facebook for updates, news and contests. www.facebook.com/HawkenEnergy.

Warm Wishes,
Donald Squire

Return this page to Hawken Energy, Inc.

- I have received and read or will read the Owners Manual completely before I install and/or fire my Hawken Energy outdoor wood boiler.
- I agree to monitor and test the water in the system according to instructions in the Owners Manual.
- I agree to burn wood only.
- I agree to use properly installed grounding rod at the outdoor wood boiler, and to use only Hawken authorized parts in my outdoor boiler installation.
- I agree to follow all the operations and maintenance procedures listed in the Owners Manual.
- I acknowledge that my failure to abide by the above shall operate to void these warranties.

Warranty Registration

Serial No. _____ Model _____ Date of Purchase _____

Name _____
 Last First Middle Initial

Street _____

City _____ State/Prov. _____ Zip/Postal Code _____

Email _____

Phone _____

How did you first hear of Hawken Boilers? _____

Rep Name _____ City _____ State _____

Owners Signature _____

(All information must be included)

I have read and understand the warranty. Acknowledgement of your warranty registration will be sent to you upon receipt by Hawken Energy Inc. If you do not receive such acknowledgment within two months, please contact your dealer/rep or Hawken Energy. Hawken Energy does not disclose this information to outside sources.

Mail to Hawken Energy, P.O. Box 351, Shelby, MI 49455

Follow these important steps to keep your warranty valid:

Rake ashes in primary fire box. Do not allow ashes to build up on steel surfaces in firebox.

Remove ashes from secondary burn chamber every three days or as needed.

Do not overfill your boiler. Do not use the inner door shield to force wood or ashes into the firebox.

Clean the rear heat exchanger every 2 weeks or more often if needed to maintain efficiency.

Submit a water sample to Hawken for testing at least once every 12 months. Add water treatment as needed according to the instructions in the Owner's Manual.

Add water to the boiler as needed. Do not operate the boiler with low water levels.

Inspect door rope seals and replace as needed

Follow all maintenance and other instructions specified in the Owner's Manual.

20 Year Limited Warranty



Hawken Energy, Inc. (“Hawken Energy”) warrants to the first retail purchaser that the parts manufactured by Hawken Energy and included as part of the furnace known as GX Series shall be free from defects in workmanship. This warranty is effective for a period of twenty years from the date of purchase; provided that the first retail purchaser timely complied with the warranty registration requirements described below. Upon notice of a warranty claim, Hawken Energy shall have the option of repairing or replacing the defective part or refunding the purchase price of the furnace.

Hawken Energy further warrants to the first retail purchaser that the firebox assembly of the GX Series furnaces shall be free from corrosion. This warranty is effective for a period of twenty (20) years from the date of purchase; provided that the first retail purchaser timely complied with the warranty registration requirements described below. More specifically, Hawken Energy will provide warranty coverage due to corrosion for the cost of the parts only, based on the following pro-rated scale: for years one through five at 100% of Factory Retail Prices; for years six and seven at 75% of Factory Retail Prices; for years eight through ten at 40% of Factory Retail Prices; and in the years eleven through twenty at 25% of Factory Retail Prices. Upon notice of such a warranty claim, Hawken Energy shall have the right to replace or repair the parts at its option.

Hawken Energy further warrants to the first retail purchaser that the electrical components in the GX Series furnaces shall be free from defects during normal usage for a period of one year from the purchase date; provided that the first retail purchaser timely complied with the warranty registration requirements described below. Upon notice of such a warranty claim, Hawken Energy shall have the option to replace or repair the defective components.

Hawken Energy reserves the right to modify the design of any furnace at any time and for any reason.

The liability of Hawken Energy shall not exceed the repair or replacement value of the defective parts and does not include any costs for labor to remove and reinstall the alleged defective part, transportation to and from the factory, the costs of plumbing, the costs of replacement water or water additives, and any other materials required to make the repair. The warranties described above do not cover defects, corrosion or malfunctions resulting from: (i) failure to properly install, operate or maintain the furnace in accordance with Hawken Energy’s published Owner’s Manual; (ii) the workmanship of any installer or repairman of the furnace; (iii) abuse, misuse, alteration, accident, fire, flood, negligence or acts of God; (iv) freezing or overheating; (iv) any unauthorized work or alterations to the furnace; (v) improper water treatment or ash removal procedures, or (vi) normal wear items including without limitation door gaskets, paint, chimney components, firebrick, cleaning tools, catalytic combustor, and air deflector.

These are the only warranties given by Hawken Energy as regarding GX Series furnaces. No one is authorized to make any other warranties on Hawken Energy’s behalf. **THESE WARRANTIES ARE IN LIEU OF ALL OTHER WARRANTIES, EXPRESS OR IMPLIED, INCLUDING BUT NOT LIMITED TO ANY IMPLIED WARRANTIES OF FITNESS FOR A PARTICULAR PURPOSE OR MERCHANTABILITY. HAWKEN ENERGY EXPRESSLY DISCLAIMS AND EXCLUDES ANY LIABILITY FOR CONSEQUENTIAL, INCIDENTAL, INDIRECT OR PUNITIVE DAMAGES FOR BREACH OF ANY EXPRESS OR IMPLIED WARRANTY.** Defects in components incorporated into the furnace (including, the aquastats, pumps and fans) but not manufactured by Hawken Energy, shall be governed by the terms and conditions of the relevant component manufacturer’s warranties, if any. Other furnace models, including HE-750, HE-1000, HE-1100, HE-2000, HE-2100, HE-3000, HE-4000, and HE-5000 are covered under a separate warranty.

In order for the warranties described above to be effective, the first retail purchaser must deliver a signed warranty registration in the form below to Hawken Energy within fifteen (15) days of purchasing the furnace along with a copy of the original invoice from the dealer or representative conducting the sale.